

HE4 Honer/Edger

*Just right for mid-sized processors and
sharpening services*



PRIMEEdge®
COZZINI CUTTING EDGES
AND SHARPENING SOLUTIONS

HE4 Honer/Edger

- The HE4 can Hone/Edge up to 400 blades per day.
- Hones/edges blades up to 10" (254mm) long.
- Unique spiral-shaped honing/edging stone design assures consistent, smooth, sharp edges.
- Recirculating liquid coolant system provides burn-free and dust-free operation.
- Integrated stone dressing system maintains roundness of the stones for perfect, consistent, sharp edges.
- CE approved.

REV 06/14/2018

PRIMEEdge®
COZZINI CUTTING EDGES
AND SHARPENING SOLUTIONS

877-322-EDGE(3343) • primedge.com • sales@primedge.com • Fax:224-265-6638

HE4 Honer/Edger

Ideal for medium-volume processors and sharpening services, the **PRIME**Edge **HE4** Honer/Edger is capable of sharpening up to 400 knives per day. The **HE4** can sharpen knives up to 10" (254mm) long and includes an integrated stone dressing system to maintain the roundness of the stones for perfect, consistent, sharp edges.

The **PRIME**Edge **HE4 Honer/Edger** utilizes two 4-inch spiral threaded honing wheels. The wheels are overlapped a predetermined amount to create the desired cutting edge angle. Hollow grinding and honing are done under a flow of coolant to ensure clean, smooth, burr-free edges time after time without scorching or burning. A few passes of the blade across the specially designed honing/edging wheels produces a keen, sharp, cutting edge.

The **PRIME**Edge **HE4** consists of a cast aluminum body housed under a durable, easy-to-clean, fiberglass cover. The ergonomic design of the HE4 is designed to provide the operator with maximum comfort and ease of operation while honing/edging blades. An adjustable, pivoting lamp can be oriented in different positions for excellent visibility while sharpening blades. The HE4 also comes with a cart for easy portability.

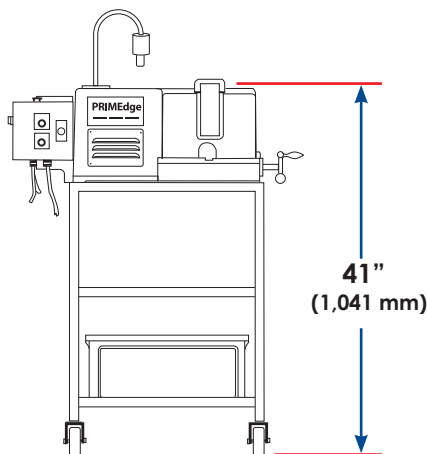
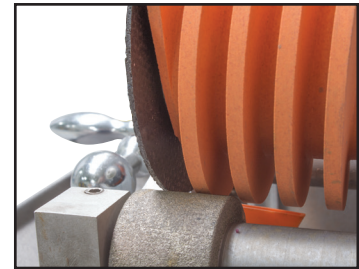
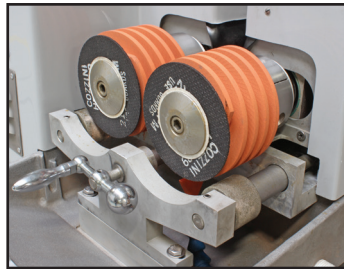
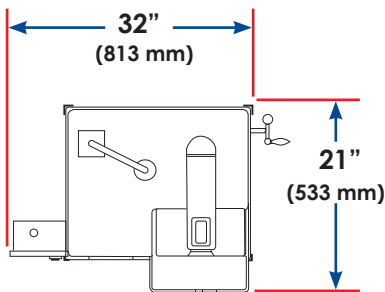

HE4 Knife Sharpening System			
Voltage	Frequency	HP	kW
115V	50 or 60 Hz	1/2	.38
220V			
115V		1/3	.25
220V			

PRIMEEdge[®]
COZZINI CUTTING EDGES
AND SHARPENING SOLUTIONS

877-322-EDGE(3343) • primedge.com • sales@primedge.com • Fax:224-265-6638

PRIME

PRIMEEdge, Inc. • Cutting Edges • Knife Sharpening Systems • Edge Maintenance Tools • Professional Sharpening Services
Circular Blade & Grinder Plate Sharpeners • Grinder Plates, Knives & Accessories • Sanitizer/Bacteria Reduction Washing Systems